















PHBS32004Z - Klokarmatuur PHB S3 200W 4000K Zhaga



Power High Bay 200W 4000K. De IP65 behuizing met geïntegreerde ventilatiesleuven garandeert een optimale luchtdoorstroming en koeling. PHB is uitgerust met performante 3030 Lumileds met zeer lange levensduur. PHB beschikt over ENEC certificatie en is standaard voorzien van een opaal polycarbonaat cover voor een aangename en minder verblindende verlichting. Toestelrendement tot 160lm/W bij 4000K, standaard lichtbundel van 90°. Met de optionele muurbeugel is het mogelijk om het toestel in een vaste positie te monteren op wand of plafond. Klaar voor smart lighting toepassingen. Raadpleeg ons hoofdstuk smart lighting voor meer informatie. Inclusief aansluitkabel van 30cm.

														
IP65	IK09	90	5	tot 160	0,90	70.000 L80B50	Flicker-Free	80	4000	NEE	SMD2835	28	JA	NEE

Technische eigenschappen

Referentie	PHBS32004Z
EAN code	5420076297695
ETIM code	EC001716

Elektrische eigenschappen

Systeem vermogen (W)	200W/-10%
LED vermogen (W)	190W+/-10%
Aansluitspanning (Vac)	100-277
Frequentie (Hz)	50/60
Driver inbegrepen	ja
Driver intern/extern	intern
Driver merk	TOMCARLINE
Driver type	RD240
Dimbaar	nee
Flicker free	nee
Power factor	0,90
THD	<15%
Driver output (V)	250V+/-10%
Driver output (mA)	760+/-10%
Isolatieklasse	I
Energie klasse	D
Aantal op 16A B curve	4
Aantal op 16A C curve	6
Aantal op 16A D curve	8
Inrush current driver	

Garantie en certificatie

ENEC	ja
Garantie (jaar)	5 (exclusief batterijen)

Lichttechnische eigenschappen

Lichtbundel(°)	90
Kleurtemperatuur (K)	4000
Kleurweergave CRI	80
UGR	28
Kleurvastheid SDCM	<5
Lumen output (Lm)	32000
Lm/W	160
Flux code	
Ledchip	SMD2835
Ledfabrikant	
Aantal LEDs	232
Fotobiologische klasse	RG1

Afmeting en materiaal eigenschappen

Afmetingen (LxBxH)	330x330x105mm
Gewicht (kg)	3
Kleur	zwart
Werktemperatuur (°C)	-30~+50
IP waarde	IP65
IK waarde	IK09
UV bestendig	nee
Zeewater bestendig	nee
UL 94	
Aantal in bulk	1
Aantal op pallet	117
Minimum bestelaantal	1
Stockartikel	nee
EPA	

PHBS32004Z - Klokarmatuur PHB S3 200W 4000K Zhaga

Lumen distributio

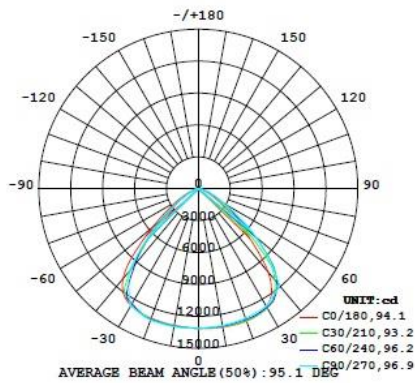

Distance curve:

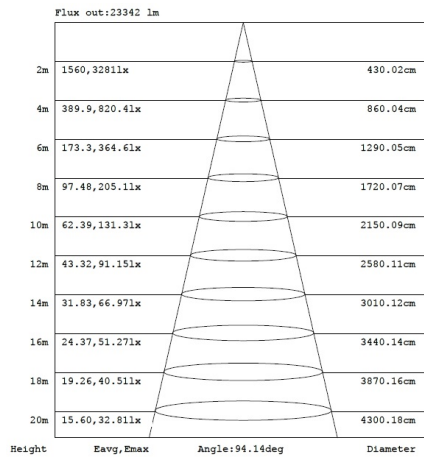

Spectrum distributio

Lumendrop

PHBS32004Z - Klokarmatuur PHB S3 200W 4000K Zhaga

Afmetingen

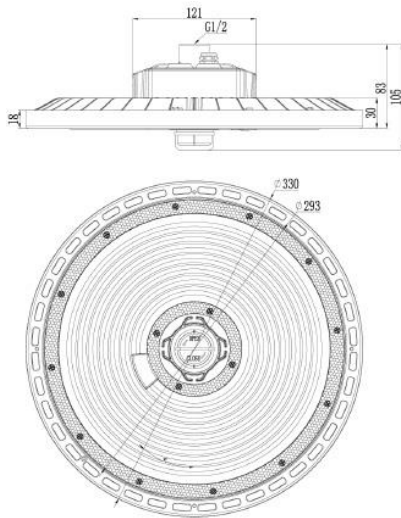

Aansluitschema